



Online Application No 23860

[I-21/130/2026-W&M Section]
GOVERNMENT OF INDIA/भारत सरकार
MINISTRY OF CONSUMER AFFAIRS, FOOD AND PUBLIC DISTRIBUTION
उपभोक्ता मामले, खाद्य एवं सार्वजनिक वितरण मंत्रालय
DEPARTMENT OF CONSUMER AFFAIRS/ उपभोक्ता मामले विभाग
LEGAL METROLOGY DIVISION/ विधिक मापविज्ञान प्रभाग

Krishi Bhawan/कृषि भवन, नई दिल्ली
Dated/दिनांक- : 08.05.2026

Certificate of Approval of Model/ मॉडल का अनुमोदन प्रमाणपत्र

Whereas the Central Government, after considering the report submitted to it by the prescribed authority, is satisfied that the model described in the said report is in conformity with the provisions of the Legal Metrology Act, 2009 (1 of 2010) and the Legal Metrology (Approval of Models) Rules, 2011 and the said model is likely to maintain its accuracy over periods of sustained use and to render accurate service under varied conditions;

Now, therefore, in exercise of the powers conferred by section 22 of the Legal Metrology Act, 2009 (1 of 2010) read with sub-rule (6) of rule 8 and sub-rule (4) of rule 11 of the Legal Metrology (Approval of Models) Rules, 2011, as per Schedule Seventh of the Legal Metrology (General) Rules, 2011, the Central Government hereby issues the certificate of approval of the model of non-automatic weighing instrument with digital indication of series "COPTT1" and with brand name "CONWEIGH PLUS" (hereinafter referred to as the said model), manufactured by M/s CONWEIGH PLUS INSTRUMENTS CO., 2401, NAHARGARH ROAD, RANGESHWAR MAHADEV KI GALI, JAIPUR-302001(RAJASTHAN) and which is assigned the approval mark IND/09/26/206 (the picture of model is given below as figure 1);

Technical Data:

Type of Instrument	Electronic Table top Weighing Machine
Accuracy Class	Special Accuracy (I)
Maximum Capacity	300g
Minimum Capacity	100mg
Verification Scale Interval	1 mg
Power Supply	230V, 50Hz AC
Display Unit	LCD
Tare	Subtractive
Working Principle	EMFC
Software Version	U18.0
Checksum	0970



Figure 1

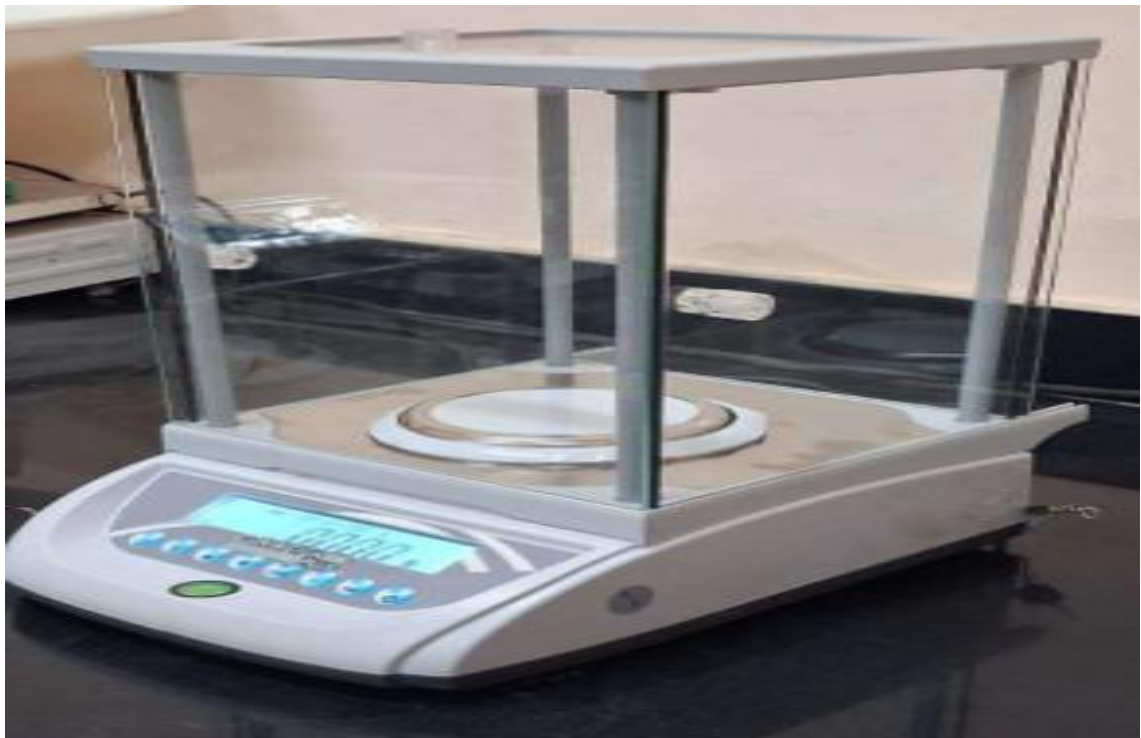

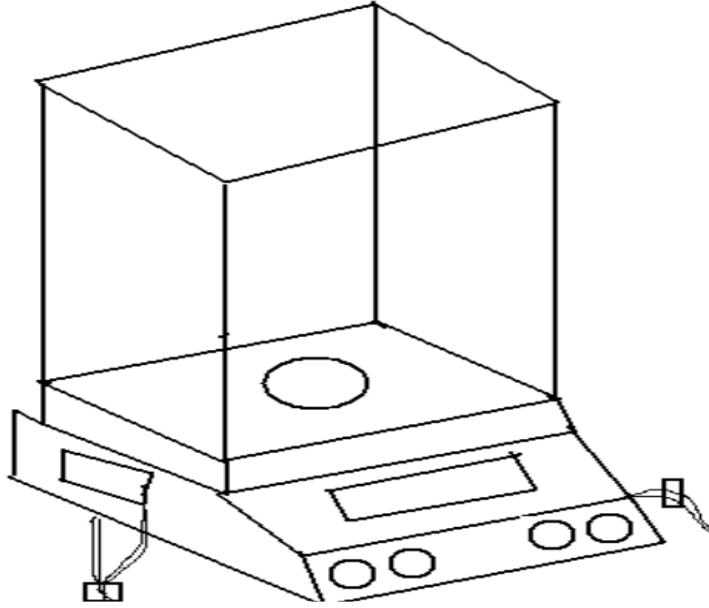

Figure 2

Sealing is done by passing the sealing wire through the holes provided on the body of machine. A lead seal is put at the end of the wire for stamping purpose (a typical schematic diagram of sealing provision to prevent the fraudulent practices of the model is given above as Figure 2). A dip switch has also been provided in mother board/PCB to disable access to external calibration.

Further, in exercise of the power conferred by sub-rule (9) of rule 8 of the Legal Metrology (Approval of Models) Rules, 2011, the Central Government hereby declares that this certificate of approval of the said model shall also cover the weighing instruments of similar make, accuracy and performance of same series with capacity up to 300g with number of verification scale interval (n) 50000 or more for 'e' value of 1mg or more with 'e' value of 1×10^k , 2×10^k or 5×10^k , where k is a positive or negative whole number or equal to zero manufactured by the same manufacturer in accordance with the same principle, design and with the same materials with which, the said approved model has been manufactured.

[F.No. I-21/130/2026-W&M Section]



(Ashutosh Agarwal/आशुतोष अग्रवाल)
Director (Legal Metrology) to Govt. of India/ निदेशक (विधिक माप विज्ञान) भारत सरकार
Phone/दूरभाष01123389489
Email/ई-मेल: dirwm-ca@nic.in